

APZ1

SHOWER DRAIN WITH AN EDGE FOR PERFORATED GRIDS



Application:

- For indoor use
- For drainage of floor level showers
- It can therefore be placed in open spaces or near the wall of the shower area
- For perforated stainless steel grids
- For wheelchair access

Features:

- Linear drains made from stainless steel (hardened materials by pickling, passivation and electrochemical polishing)
- Installation height from 85 mm
- Adjustable height
- The trap is firmly connected to the drain channel – 100% waterproofing
- Self-adhesive tape for quality waterproofing
- Completely cleanable trap up to the waste pipe
- The collar and trap are protected by foil, and the channel itself by a polystyrene insert
- The high flowrate achieved is due to the double compartment trap system
- Option to buy a combined odour trap
- 25 years warranty
- Linear drain material: stainless steel AISI 304, DIN 1.4301, ČSN 17240
- Trap material: polypropylene

Standards:

ČSN EN 1253

Technical parameters:

Trap	50 mm
Flow rate	60 – 68.8 l/min
Resistance of odour traps against pressure	982 Pa
Waste outlet diameter	50 mm
Minimum thickness of concrete	85 mm
Total installation height	100 – 158 mm
Load class – K3	300 kg

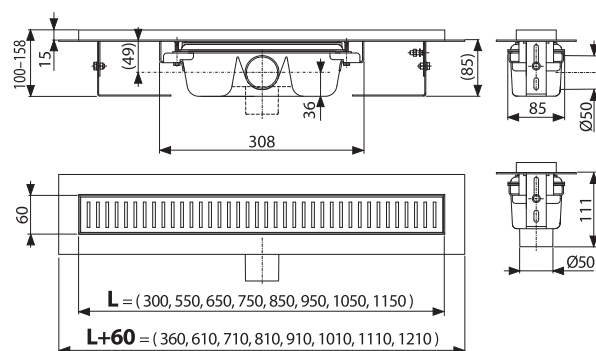
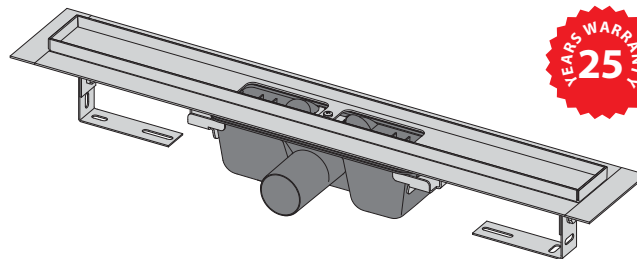

Scope of supply:

- The linear drain is assembled with the odour trap
- Anchoring set: screw Ø6x50 – 2 pcs, dowel Ø10 – 2 pcs
- Self-adhesive waterproofing tape
- Collar and odour trap inlets are covered by protective foil
- Installation channel cover
- Hardware for anchoring the adjustable legs: screw M6x12 – 2 pcs

Order number:

Code	EAN	Linear drain length	Weight (piece)	Dimensions (piece)	Quantity (packing)	Quantity (pallet)
APZ1-300	8594045939194	300 mm	1.9548 kg	385×175×130 mm	9 pcs	144 pcs
APZ1-550	8594045939200	550 mm	2.842 kg	620×170×135 mm	12 pcs	36 pcs
APZ1-650	8594045932928	650 mm	3.114 kg	720×170×135 mm	12 pcs	36 pcs
APZ1-750	8594045932935	750 mm	3.3596 kg	820×170×135 mm	12 pcs	36 pcs
APZ1-850	8594045932942	850 mm	3.5686 kg	920×170×135 mm	12 pcs	36 pcs
APZ1-950	8594045932959	950 mm	3.8509 kg	1020×170×135 mm	12 pcs	36 pcs
APZ1-1050	8594045932966	1050 mm	4.0954 kg	1120×170×135 mm	12 pcs	36 pcs
APZ1-1150	8594045939897	1150 mm	4.2962 kg	1120×170×135 mm	12 pcs	36 pcs

Custom-made product solution:

Non-standard sizes and other special solutions can be supplied as an individual project on order (length, shape, placement of the odour trap, a type of stainless steel, etc.).